

## WHOLE-HOUSE DUCT MOUNT HEPA AIR CLEANER



### Description

- The Five Seasons Whole House Duct Mount HEPA Air Cleaner has been designed to remove atmospheric and household dust, coal dust, insecticide dust, mites, pollen, mold spores, fungi, bacteria, viruses, pet dander, cooking smoke and grease, tobacco smoke particles, and more down to 0.3 micron (1/84,000 of an inch) with 99.97% efficiency on the first pass of air.
- It's ideal for homes that have tight space conditions in their furnace/air conditioning rooms. This unit is compact and can be installed directly on the return air vent. It can also be mounted directly to the furnace and collar mounted to the return air duct to save space.
- Ideal for homes with allergy, asthma or respiratory sufferers, smokers, pets, cooking odors and mustiness.
- Helps protect and prolong the operating efficiency of the heating and cooling equipment.

### Standard Features

- Highly Efficient MERV 11 Prefilter removes lint and hair before they enter HEPA filter.
- Activated Carbon Prefilter removes odors to extend the life of the HEPA filter.
- Long-life, 99.97% HEPA Media Filter removes particles 0.3 micron (1/84,000 of an inch) and larger. The HEPA filter becomes more efficient as it becomes dirtier with time.
- Powerful European motor delivers 320 CFM (FSHEPADM400) or up to 320 CFM (FSHEPADM400-VS) of pure air, without adding static pressure to the HVAC system.
- Plug-in Power Cord provides convenient electrical connection.
- Versatile installation can be duct mounted, collar mounted or free-standing.

### Cabinet Construction Features

- One piece wrap, steel cabinet has powder-coat paint finish to provide rigid installation and durability.
- Pre-punched openings at back of unit and mounting template are provided for easier duct mount installation; no external ducting required.
- Pre-punched openings at top and bottom of unit facilitate collar mount installation.

### Media Replacement Filters

PART NUMBER	DESCRIPTION	REPLACE EVERY
DMH4-0400	HEPA Media Filter	2-3 years
DMH4-0855	Prefilter, MERV 11	3-6 months
DMH4-0810	Carbon Prefilter	3-6 months

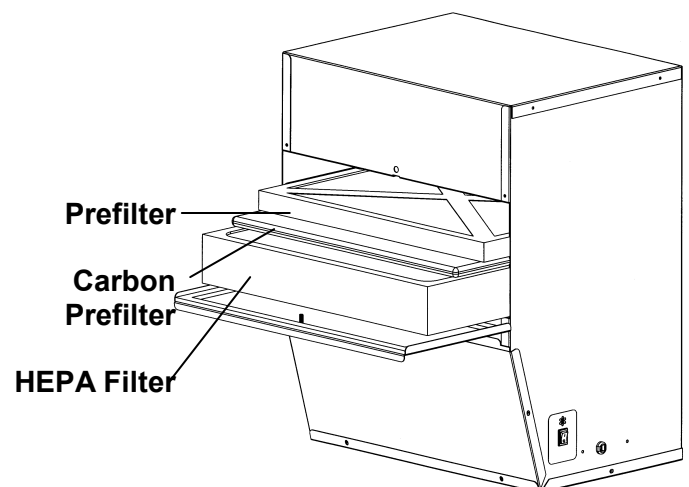

## SPECIFICATIONS

MODELS	FSHEPADM400, FSHEPADM400-VS
<b>Air Flow:</b> FSHEPADM400 FSHEPADM400-VS	320 CFM/ 544 m <sup>3</sup> /hr Up to 320 CFM/ Up to 544 m <sup>3</sup> /hr
<b>Whole-House Air Changes Per Day</b> 1500 sq ft home 2000 sq ft home	39 Air Changes / Day 29 Air Changes / Day
<b>Prefilter (MERV 11)</b>	3.1 ft <sup>2</sup> 0.29 m <sup>2</sup>
<b>Carbon Prefilter</b>	1.33 ft <sup>2</sup> 0.12 m <sup>2</sup>
<b>HEPA Media Filter</b>	40 ft <sup>2</sup> 3.7 m <sup>2</sup>
<b>Power</b>	120 V 60 Hz
<b>Plug-in Power Cord</b>	10.0 ft 3.05 m
<b>Cabinet Dimensions</b> <i>WxDxH</i>	16.25 x 12.75 x 20.13 in 41.3 x 32.4 x 51.1 cm
<b>Intake Duct Fitting</b>	14.5 x 3.75 in or 8 in (dia) 36.8 x 9.5 cm or 20.3 cm (dia)
<b>Outflow Duct Fitting</b>	14.5 x 4.37 in or 8 in (dia) 36.8 x 11.1 cm or 20.3 cm (dia)
<b>Unit Weight</b>	38 lbs 17.2 kg

### DUCT MOUNT INSTALLATION

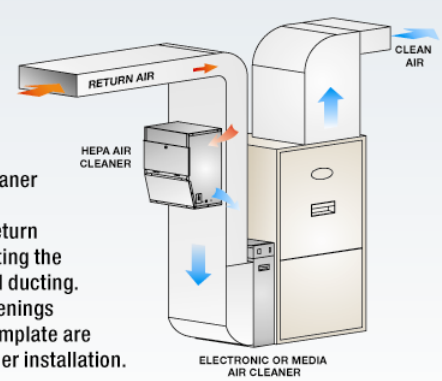

The HEPA Air Cleaner can be installed directly on the return air duct, eliminating the need for external ducting. Pre-punched Openings and Mounting Template are provided for easier installation.

ELECTRONIC OR MEDIA AIR CLEANER

### COLLAR MOUNT INSTALLATION

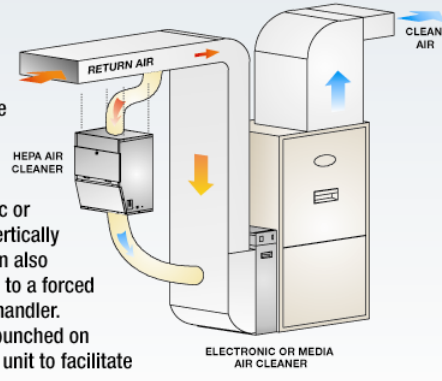

The HEPA Air Cleaner can also be installed with collars and flexible ducting for self contained installation such as in the attic or garage. Mounts vertically or horizontally. Can also be collar mounted to a forced air furnace or air handler. Openings are prepunched on top and bottom of unit to facilitate installation.

ELECTRONIC OR MEDIA AIR CLEANER

## HOW IT WORKS

Millions of airborne particulates and gases travel through the heating/cooling system 4-5 times every hour. The HEPA Air Cleaner connects to the return air duct and diverts 1/3 to 1/2 of this dirty air through a sealed 3-stage filtration system. A home can reach 39 or more whole-house air changes/day depending on the house size. And when a Five Seasons High Efficiency Electronic or Media Air Cleaner is added to the return air, the home can achieve 96+ whole-house air changes/day (with system fan on continuous).

Manufacturer reserves the right to discontinue or change at any time, specifications or designs without notice or without incurring obligations. Performance of the Air Cleaners will depend on house plan design, duct design and heating/cooling equipment.

# **Five Seasons.**

**FIVE SEASONS COMFORT LIMITED**

351 North Rivermede Road, Concord, Ontario, Canada L4K 3N2

Tel: (416) 213-5636 Fax: (416) 213-5593

**Toll Free North America: 1-800-267-8305**

Email: [info@fiveseasonsaircleaners.com](mailto:info@fiveseasonsaircleaners.com)